

**FOR MORE INFO CONTACT:**  
**American Crane & Equipment Corp.**  
**Authorized Distributor**  
**Tel: 877-503-2972**  
**Fax: 484-945-0430**  
**Email: sales@americancrane.com**  
**www.americancrane.com**

- A 25 1/2"
- B 6 3/8"
- C 10 1/2"
- D 5"
- E 5"
- F 3 1/4"
- G 5 3/4"
- \* H 1 11/16"
- \* I 1 13/16"

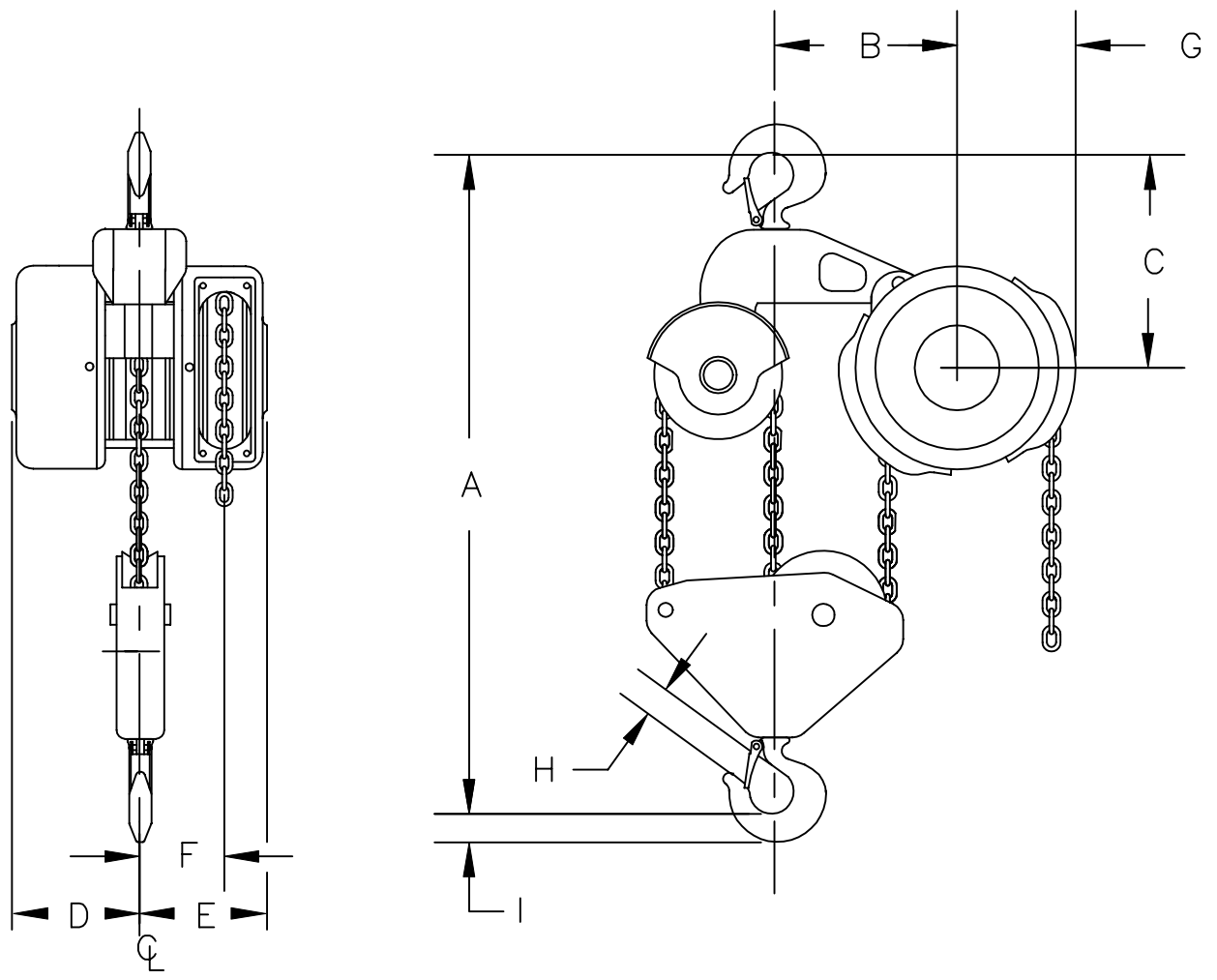

\* DIM. FOR TOP & BOTTOM HOOK

MK.	REVISIONS	CK-DATE

5 & 6 TON  
 HOOK SUSPENDED SPUR GEARED HOIST  
**CHESTER HOIST**  
 LISBON, OHIO

DR. RLB	TR.	CK.	AP.
SCALE NONE		DATE 6-19-00	
REF. DWG. NO.		5ZSGH	
Dwg. No. CD023			