



**AMERICAN CRANE  
& EQUIPMENT CORPORATION**  
DOUGLASSVILLE, PA. 19518 U.S.A.  
PHONE: 610-385-6061  
FAX: 610-385-3191

**3161  
TOP RUNNING TROLLEY**

**30 TON CAPACITY**

**PRODUCT INFORMATION**

DWG. NO:

**3161B-1426**

DATE: 10/21/04

REVISION:

1

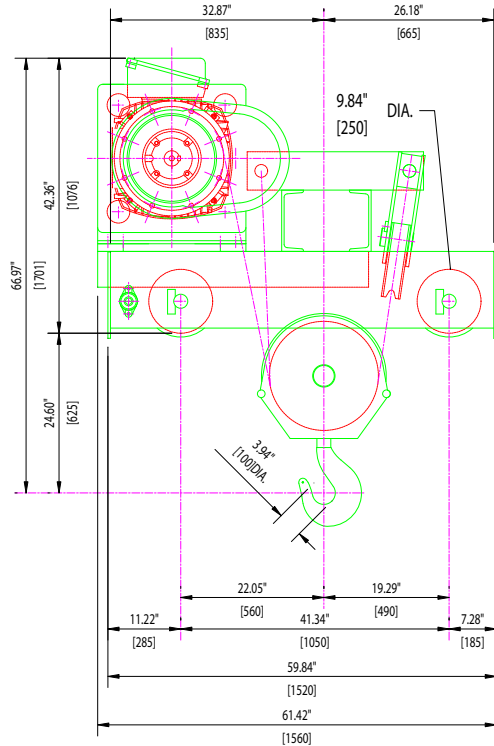
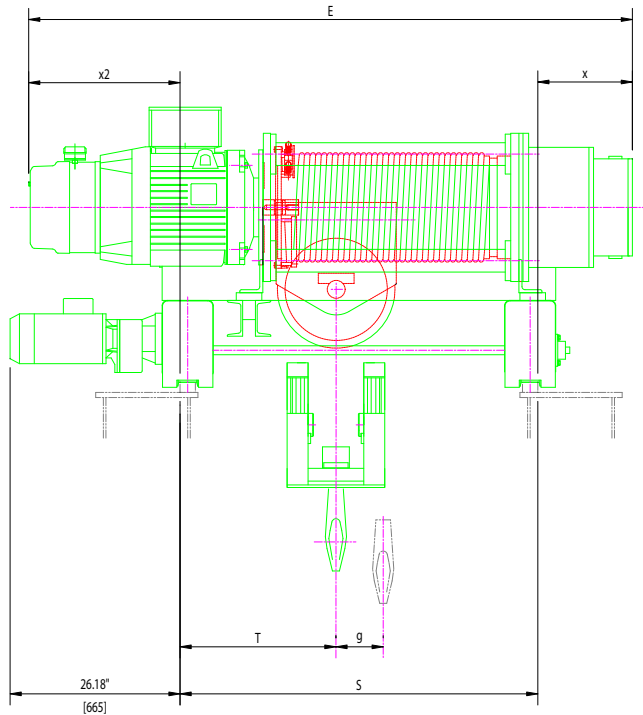

ACECO RESERVES THE RIGHT TO MAKE CHANGES WITHOUT NOTICE.

**HOIST TECHNICAL DATA**

CAPACITY:	30 TONS [60000 LBS]	HOIST CLASS:	HMI H4	HOIST MOTOR:	50/8 HP AT 1800/300 RPM TEFC, S3 - 40%, CLASS "F" INSULATION
HOIST SPEED:	20/4 FPM	POWER SUPPLY:	460-3PH-60HZ		
TROLLEY SPEED:	83/20 FPM	HOIST MOTOR:	6275-69	TROLLEY MOTOR:	2.4/6 HP AT 3260/780 RPM TEFC, S3 - 40%, CLASS "F" INSULATION
		TROLLEY MOTOR:	9100-1575R08G		

**DIMENSIONAL INFORMATION**

HOIST TYPE	HEIGHT OF LIFT		S INCHES (mm)	T INCHES (mm)	g1 INCHES (mm)	x1 INCHES (mm)	x2 INCHES (mm)	E INCHES (mm)	WEIGHT LBS (KG)
	METERS	FEET							
3161B-1426	10.75	35'-2"	55.11 (1400)	24.01 (610)	7.28 (185)	-	-	93.70 (2380)	5368 (2435)
3161B-2426	15.75	51'-7"	82.67 (2100)	36.02 (915)	10.82 (275)	-	-	115.75 (2940)	5754 (2610)
3161B-3426	-	-	-	-	-	-	-	-	-
3161B-4426	20.75	68'-0"	110.23 (2800)	49.21 (1250)	14.17 (360)	-	-	129.92 (3300)	6360 (2885)
3161B-5426	23.75	77'-11"	110.23 (2800)	45.27 (1150)	16.14 (410)	-	-	137.40 (3490)	6470 (2935)
3161B-6426	28.0	92'-0"	125.98 (3200)	49.21 (1250)	19.09 (485)	-	-	149.20 (3790)	6746 (3060)
3161B-7426	32.5	106'-7"	-	-	-	-	-	-	-
3161B-8426	-	-	-	-	-	-	-	-	-
3161B-9426	35.5	116'-5"	-	-	-	-	-	-	-