



**AMERICAN CRANE  
& EQUIPMENT CORPORATION**  
DOUGLASSVILLE, PA. 19518 U.S.A.  
PHONE: 610-385-6061  
FAX: 610-385-3191

**LOW HEADROOM  
MONORAIL TROLLEY**

**1 1/2 TON CAPACITY**

**PRODUCT INFORMATION**

DWG. NO:

**3101D-1223**

DATE: 23.4.01

REVISION: B

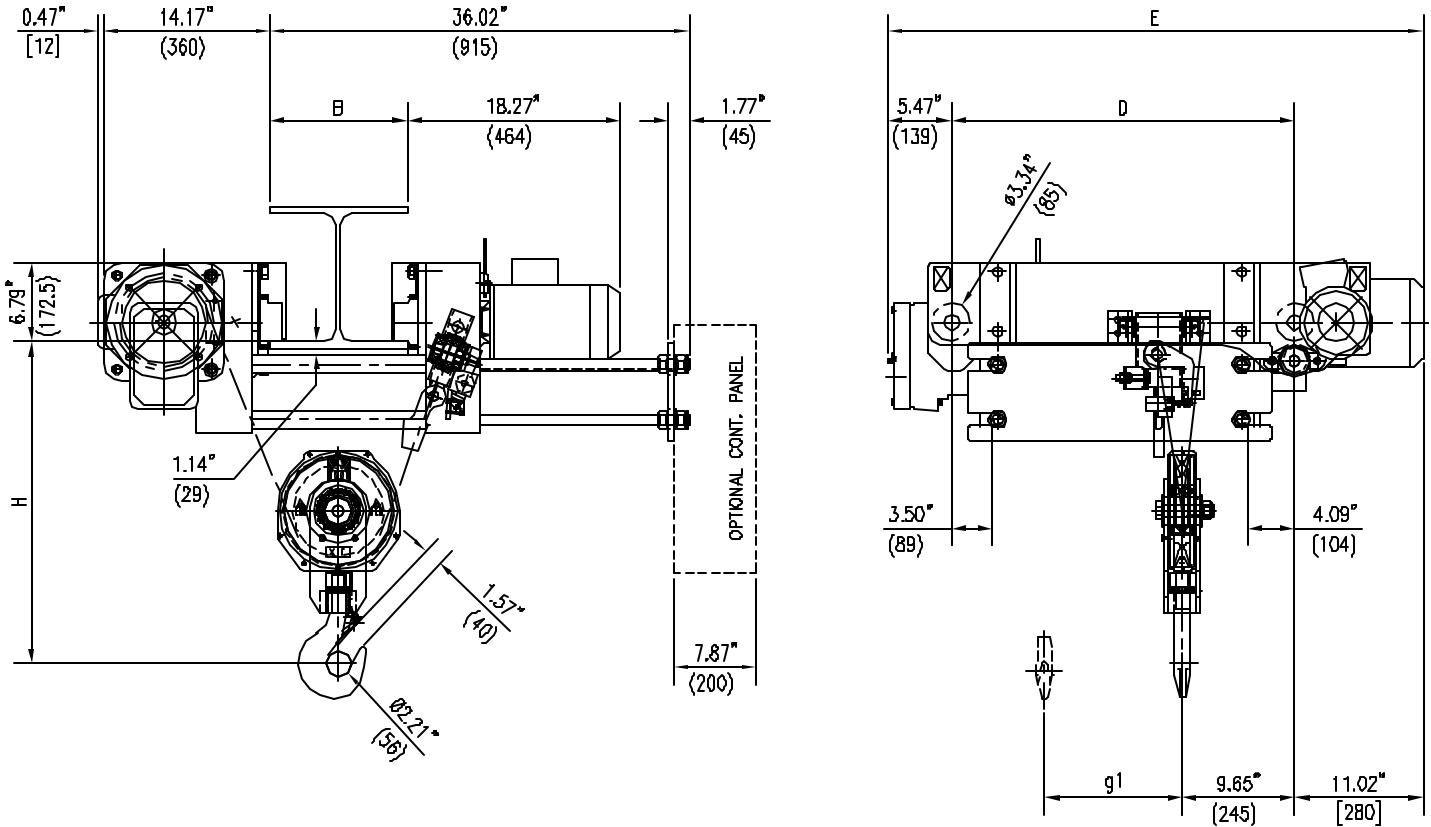

ACECO RESERVES THE RIGHT TO MAKE CHANGES WITHOUT NOTICE.

**HOIST TECHNICAL DATA**

CAPACITY:	1 1/2 TONS (3000 LBS)	HOIST CLASS:	HMI H4	HOIST MOTOR:	4/1 HP, 3600/900 RPM, TEFC, S3 - 30%, CLASS "F" INSULATION
HOIST SPEED:	32 / 8 F.P.M. { OPT. SPEEDS AVAILABLE }	POWER SUPPLY:	460V-3PH-60HZ		
TROLLEY SPEED:	67 / 15 F.P.M. { OPT. SPEEDS AVAILABLE }	HOIST MOTOR:	6275-51	TROLLEY MOTOR:	4/1 HP, 3600/900 RPM, TEFC, S3 - 60%, CLASS "F" INSULATION
		TROLLEY MOTOR:	9100-1035R08G		

**DIMENSIONAL INFORMATION**

HOIST TYPE	HEIGHT OF LIFT		g1 INCHES (mm)	D INCHES (mm)	E INCHES (mm)	WEIGHT LBS ( KG )	FLANGE WIDTH "B"		HEADROOM "H"	
	METERS	FEET					mm	INCHES	mm	INCHES
3101D-1223	14.2	46'-7"	8.27 ( 210 )	29.45 ( 748 )	45.94 ( 1167 )	737 ( 335 )	≤ 200	≤ 7.87	700	27.56
3101D-2223	20.3	66'-7"	11.81 ( 300 )	36.54 ( 928 )	53.03 ( 1347 )	761 ( 346 )	≤ 305	≤ 12.00	700	27.56
3101D-3223	25	82'-2"	14.57 ( 370 )	42.05 ( 1068 )	58.54 ( 1487 )	781 ( 355 )	≤ 406	≤ 15.98	800	31.50
3101D-4223	34	111'-6"	19.76 ( 502 )	52.48 ( 1333 )	68.88 ( 1752 )	832 ( 378 )	≤ 500	≤ 19.68	900	35.43
3101D-5223	42.6	139'-9"	24.76 ( 629 )	62.44 ( 1586 )	78.94 ( 2006 )	849 ( 386 )	≤ 600	≤ 23.62	1000	39.37