



**AMERICAN CRANE  
& EQUIPMENT CORPORATION**  
DOUGLASSVILLE, PA. 19518 U.S.A.  
PHONE: 610-385-6061  
FAX: 610-385-3191

**TOP RUNNING TROLLEY  
W/ OPEN DECK HOIST**

**50 TON CAPACITY**

**PRODUCT INFORMATION**

DWG. NO:  
**A-20418-6050**

DATE: 07/20/09 REVISION: 0

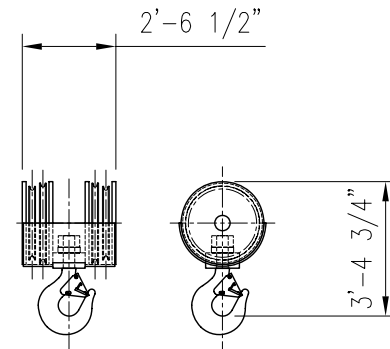
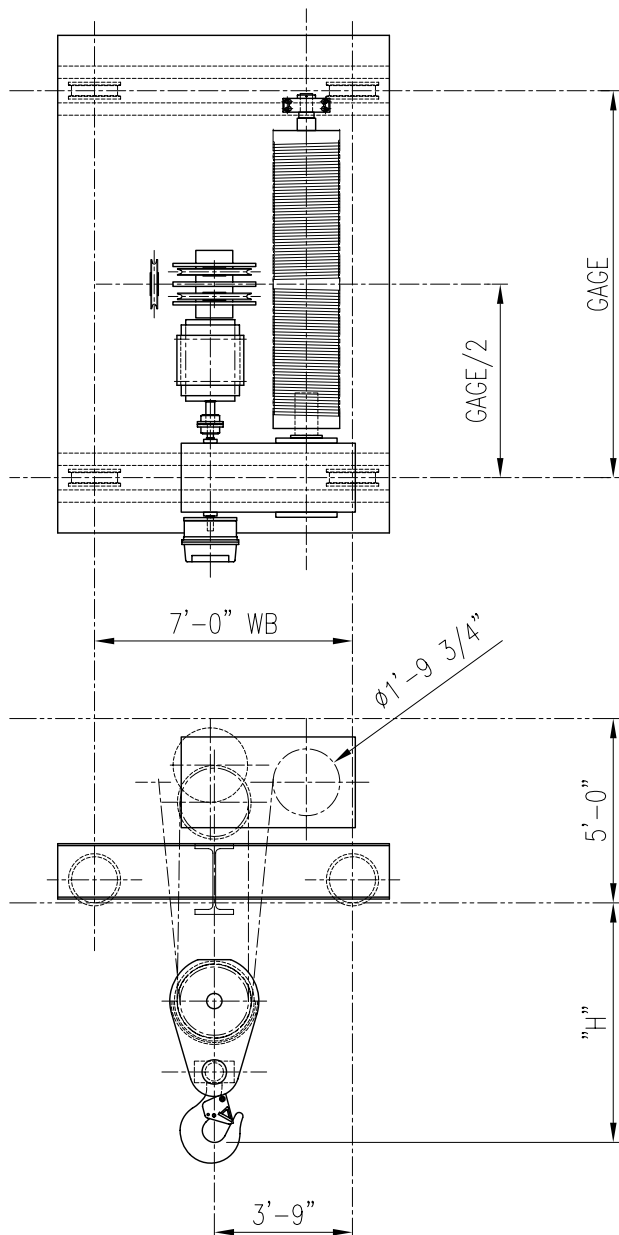

LOW HEADROOM BLOCK

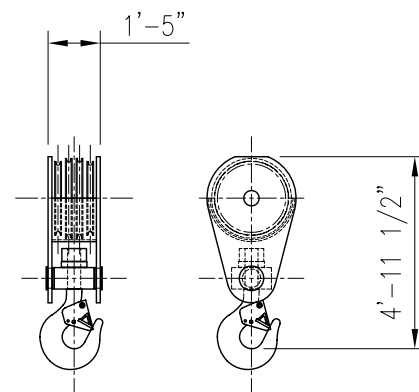

STANDARD HEADROOM BLOCK

ACECO RESERVES THE RIGHT TO MAKE CHANGES WITHOUT NOTICE.

**HOIST TECHNICAL DATA**

CAPACITY	50 TONS ( 100,000 LBS. )	HOIST SPEED	MOTOR DATA
		20 F.P.M.	75 HP / 1800 RPM
		17 F.P.M.	60 HP / 1800 RPM
CLASS	CMAA CLASS "D"	13 F.P.M.	50 HP / 1800 RPM
POWER SUPPLY	460V-3PH-60HZ		

**DIMENSIONAL INFORMATION**

MODEL NUMBER	GAGE	HEIGHT OF LIFT ON HOIST		H	
		STANDARD HEADROOM LOWER BLOCK	LOW HEADROOM LOWER BLOCK	STANDARD HEADROOM LOWER BLOCK	LOW HEADROOM LOWER BLOCK
20418-8050-10.5	10'-6"	54'-0"	44'-0"	6'-3"	4'-9"
20418-8050-11	11'-0"	59'-0"	49'-0"		
20418-8050-12	12'-0"	69'-0"	59'-0"		