



**AMERICAN CRANE  
& EQUIPMENT CORPORATION**  
DOUGLASSVILLE, PA. 19518 U.S.A.  
PHONE: 610-385-6061  
FAX: 610-385-3191

**TOP RUNNING TROLLEY  
W/ OPEN DECK HOIST**

**7.5 TON CAPACITY**

**PRODUCT INFORMATION**

DWG. NO:

**A-20418-6007**

DATE: 07/20/09

REVISION: 0

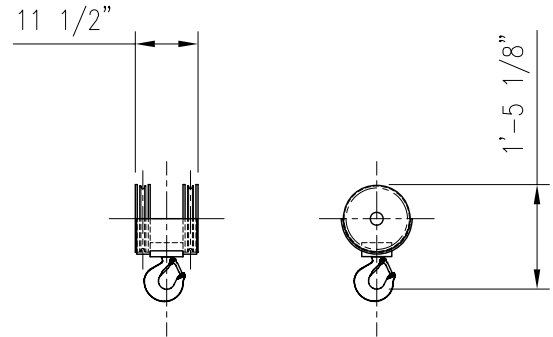
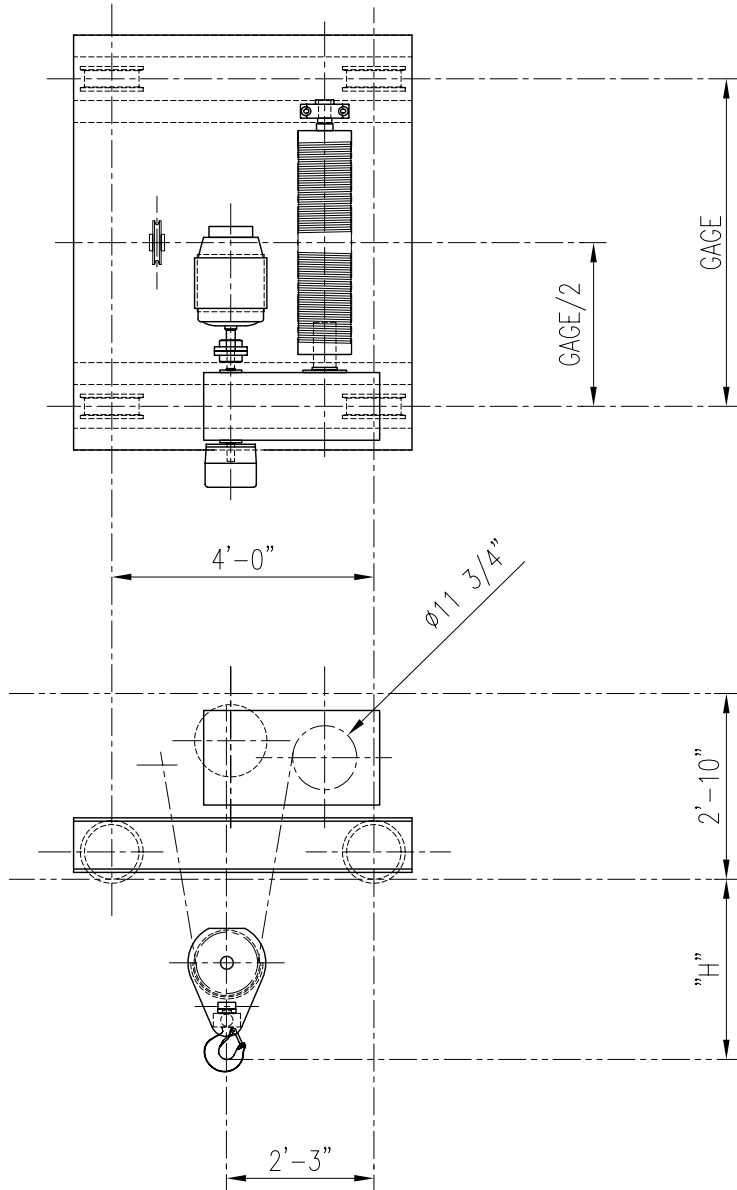

LOW HEADROOM BLOCK

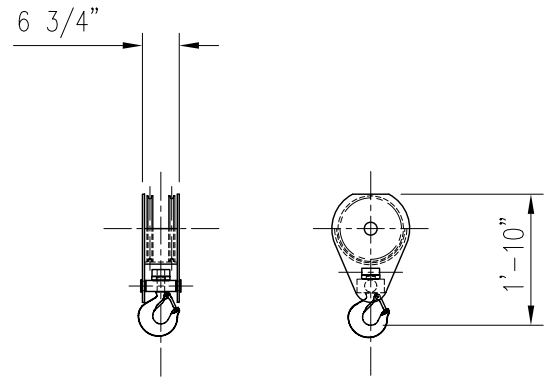

STANDARD HEADROOM BLOCK

ACECO RESERVES THE RIGHT TO MAKE CHANGES WITHOUT NOTICE.

**HOIST TECHNICAL DATA**

CAPACITY	7.5 TONS ( 15,000 LBS. )	HOIST SPEED	MOTOR DATA
CLASS	CMAA CLASS "D"	34 F.P.M.	20 HP / 1800 RPM
POWER SUPPLY	460V-3PH-60HZ	26 F.P.M.	15 HP / 1800 RPM
		18 F.P.M.	10 HP / 1800 RPM

**DIMENSIONAL INFORMATION**

MODEL NUMBER	GAGE	HEIGHT OF LIFT ON HOIST		H	
		STANDARD HEADROOM LOWER BLOCK	LOW HEADROOM LOWER BLOCK	STANDARD HEADROOM LOWER BLOCK	LOW HEADROOM LOWER BLOCK
20418-8007-5	5'-0"	41'-6"	35'-6"	2'-7"	2'-1"
20418-8007-6	6'-0"	58'-0"	52'-0"		
20418-8007-7	7'-0"	74'-6"	68'-6"		