

# PRODUCT INFORMATION

## Force-Reflecting-Manipulator IMSM

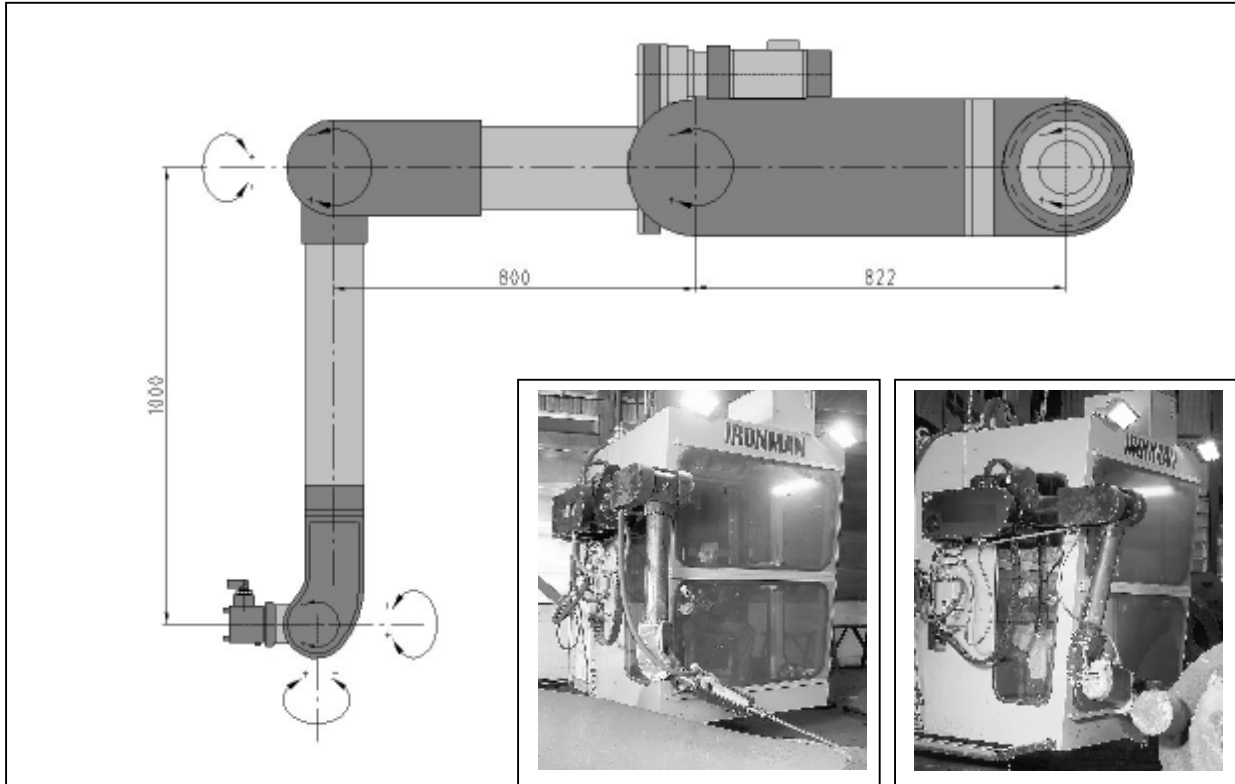

### Technical Data teleroB IMSM

load capacity - continuous operation			132 lb
load capacity - for 15 minutes			220 lb
power amplification operator / working arm			1:10, 1:20, 1:50
max. speed of tongs			40 "/sec
motor type			Servo
total weight of working arm			650 lb
shoulder (option)	32.4"	incline	± 45°
upper arm	31.5"	incline	± 45°
		rotate	± 45°
forearm	39.4"	incline	± 45°
		rotate	± 175°
wrist	6.0"	incline	+ 50° / - 135°
		rotate	± 180°
tool flange		Gripper on request	
radiation tolerance		not specified	
ambient temperature		30 - 140 °F (0 - 60°C)	

Manufacturer

Representative (North American)



teleroB Gesellschaft fuer Fernhandlungstechnik mbH  
 Vogelsangstrasse 8  
 73760 Ostfildern, Germany  
 Phone: +49 711 34102 0, Fax: +49 711 34102 555

<http://www.teleroB.com> [teleroB@teleroB.de](mailto:teleroB@teleroB.de)

Details may change without prior notice



**AMERICAN CRANE & EQUIPMENT  
 CORP.**  
 531 Old Swede Road  
 Douglassville, PA 19518 USA  
**1-877-877-5778**

[www.americancrane.com](http://www.americancrane.com)

[sales@americancrane.com](mailto:sales@americancrane.com)